

Coordinated FACTS & Fuzzy Logic based WADC for Small Signal Stability Enhancement of Multi-machine Power System

Prabodh khampariya¹, N..P. Patidar², R.P. Singh³, R.P. Singh³

¹Sri Satya Sai University of Tchnology& Medical Sciences, SehoreIndia

²Maulana Azad National Institute of Technology, Bhopal, India

nppatidar@yahoo.com; khampariya5@gmail.com; prof.rpsingh@gmail.com;

ABSTRACT—This paper presents a coordinated Wide Area Damping Controller (WADC) based on the shunt connected FACTS based controllers and simultaneous tuning of FACTS based controller and fuzzy logic based global PSS. The disturbance is symbolized as distributed in the network with consideration of momentarily disturbance to the generator in area 1 for few cycles. The tie-line active power flow from among areas, rotor speed deviation and speed, rotor mechanical angle deviation, positive sequence voltage are studied by seeing the test system with conventional PSS (CPSS), fuzzy logic based controller and coordinated fuzzy logic based PSS with shunt connected FACTS controllers specifically STATCOM and SVC. The simulation results are carried out for validation of the proposed coordinated controller.

KEYWORDS—Power system stabilizer (PSS), Wide Area Damping Controller (WADC), Static Var Compensator (SVC), Small signal Stability, Static Compensator (STATCOM).

I. INTRODUCTION

Power system nowadays is a complex network, sometimes made of thousands of buses and hundreds of generators. Available power generation usually does not situated near anuprising of load center. In order to meet the growing power demand, instead of building new transmission lines and expanding substations, utilities have a concern in better utilization of available power system capacities, existing generation and existing power transmission network [2]. On the other hand, power flows in some of the transmission lines are overloaded, which has as an overall effect of deteriorating voltage profiles and decreasing system stability and security. In addition to this, existing traditional transmission facilities, in most cases, are not designed to handle the control requirements of complex and highly interconnected power systems [1]. This situation requires the review of traditional transmission methods and practices, and the creation of new concepts, which would allow the use of existing generation and transmission lines up to their full capabilities without reduction in system stability and security. The traditional approach to damp out inter-area oscillations is through conventional Power System Stabilizer (CPSS), forming part of the generator excitation system and FACTS controllers, which employ locally available or measured signal as input [4]. These local signal based controllers lack the global observations.

In this paper, the research on detailed analysis of wide area damping controller considering FACTS based shunt controllers in coordination with fuzzy logic based global

power system stabilizer gestated to damp inter-area or low frequency oscillations in large integrated power system. Section II describes the test system taken in the analysis. In section III dynamic equations are linearized about a steady state operating point. Electromechanical oscillations and their frequency range is discussed in section IV. Fuzzy logic based global PSS and shunt connected FACTS controllers for the proposed WADC are discussed in Section V, VI and VII. In section VIII, the nonlinear simulation on interconnected multi-machine test system has been performed with PSS, fuzzy logic based global PSS and Coordinated Fuzzy with FACTS controllers to evaluate the performance of the system.

II. INTRODUCTION TO TEST SYSTEM

In spite of the high degree of activeness in recent years on wide-area control, there are many aspects remain poorly understood due to the complexity in large power system. Hence, Kundur’s benchmark two area four machine system has been carried out to analyze the different types of oscillations that occurs in the integrated power system with proposed robust coordinated fuzzy logic based PSS with FACTS wide area damping controller. In the test system all the generators are equipped with governor, AVR, and IEEE ST1A type static exciter. The loads taken here are constant impedance type and connected to bus no. 7 and 9. The structure of the case study power system is given in Fig.2.1

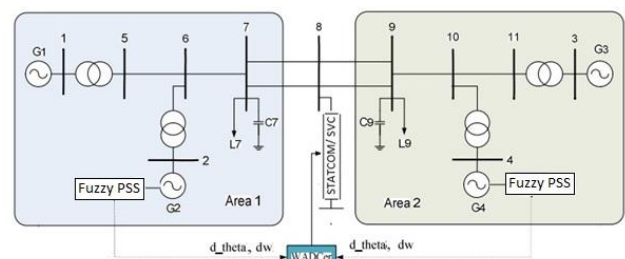

Fig 2.1: Kundur’s two area Four Machine system with Coordinated fuzzy and FACTS controllers

After the calculation of most suitable stabilizing signal and control location [6], a fuzzy logic based global PSS is employed supplement to the input of AVR along with FACTS controllers connected in shunt with the tie line connecting both the areas for the effective damping of inter area oscillations.

III. LINEARIZED MODEL

the stability of the operating point of a dynamic system to small disturbances is termed small signal stability. to test for small signal stability[1-2] the system’s dynamic

equations are linearized about a steady state operating point to get a linear set of state equations.

$$\dot{x} = Ax + Bu$$

$$y = Cx + D$$

In some small signal stability programs, the state matrices are calculated by virtue of analysis from the Jacobians of the non-linear state equalities in the Power System Toolbox, on the other hand, the linearization is performed by calculating the Jacobian numerically. In PST, states are determined from model initialization, and small disturbance is applied to each state in turn [28]. The objective of the proposed controller is aimed at achieving adequate acceptable damping for this mode. In addition to the critical mode identification, modal analysis was also performed for coherent machine identification where the one group of generators forms one area and oscillating with another group of generators. Following each rate of change of state calculation, the perturbed state is returned to its equilibrium value and the intermediate variable values are reset to their initial values. Each step in this process is similar to a single step in a simulation program.

IV. ELECTROMECHANICAL MODES

Interconnected power systems exhibit several kinds of oscillations when subjected to a perturbation. These oscillations are also named as power swings and to maintain the system stability these oscillations must be effectively damped. Oscillations in power systems are separated by the system factors. Some of the major oscillations [2] attributed to system collapse are as follows:

- 1) *Intraplant mode*: Generator units at the same power plant oscillate with each other at 2.0 to 3.0 Hz conditional on the generator capacities and connecting impedances [2].
- 2) *Local plant mode*: One generator unit swings against the rest of the generators at 1.0 to 2.0 Hz. The influence of the oscillation is confined to the generator and grid connection [2].
- 3) *Inter-area mode oscillations*: This occurrence is noticed over a great part of the power system. It includes two coherent groups of generators swinging in contradiction for each other at 1 Hz or less. The oscillation frequency is roughly 0.3 Hz [2].
- 4) *Control mode oscillations*: They are related with generators and badly regulated exciting system, turbine-governors, power controllers. Active and reactive power controllers can interact with each other [2].
- 5) *Torsional mode oscillations*: They are related with a turbine shaft in the frequency range of 10-46 Hz. Generally they are created when a multi-stage turbine is integrated to the grid via a series compensated link. [2].

V. FUZZY LOGIC BASED GLOBAL PSS

The fuzzy control system block diagram is shown in Figure 5.1. Here, a fuzzy controller embedded in a closed-loop control system. The plant outputs are

denoted by $y(t)$, its inputs are denoted by $u(t)$, and the reference input to the fuzzy controller is denoted by $r(t)$.

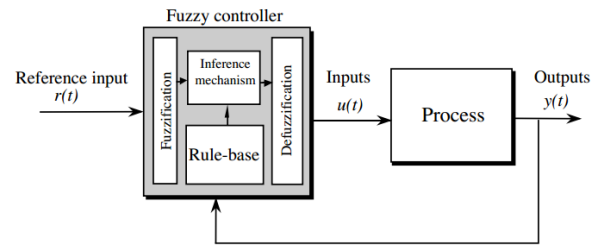

Figure 5.1: Block Diagram of Fuzzy Control System

The fuzzy controller has four main components:

- a) The fuzzification interface simply modifies the inputs and converts controller inputs into information that can be easily utilized by the inference mechanism to apply rules so that they can be interpreted and compared to the rules in the rule-base.
- b) The rule-base is a set of If-Then rules that contains a fuzzy logic quantification of the expert's linguistic description. Rule-base holds the knowledge in the form of a set of rules to achieve good control over the system.
- c) An inference engine or inference mechanism emulates the expert's decision making and evaluates which control rules are relevant at the current time and then decides what the input to the plant should be.
- d) The defuzzification interface converts the conclusions reached by the inference mechanism into the actual inputs to the plant for the process.

The proposed control scheme employs additional stabilizing control signal applied to the input of exciter through AVR, as a result an enhanced stabilizing signal through excitation systems is fed to selected individual generators involved in the controlling areas.

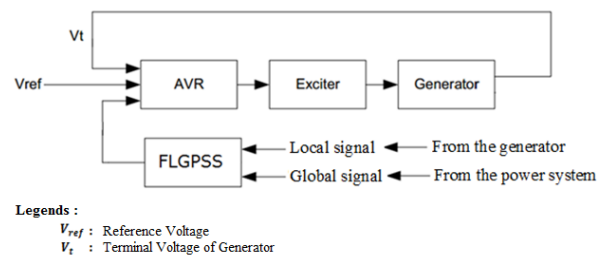

Figure 1.2: General Structure of the Proposed Control Scheme.

The rule base for the fuzzy logic controller is designed. In this research, the two inputs i.e. speed deviation and tie line active power deviation [19], result in 49 rules for each machine. The rule base employing the rules for two inputs i.e. speed deviation and tie line active power deviation is given in Table 5.1. The fuzzy logic based global PSS implemented for each area in two area four machine system is employing a global signal from power system as input to the stabilizer. The first input to the fuzzy logic controller incorporated in this research is speed deviation of respective generator and the second

input is extracted from the active power transfer across the tie-line connecting both coherent areas [17]. The output of fuzzy logic based global PSS provides the global stabilizing voltage signal for generator through its excitation system.

Table 5.1 Rule base for the Fuzzy logic based PSS

Speed Deviation	Tie Line Power						
	LN	MN	SN	ZE	SP	MP	LP
LN	LP	LP	LP	MP	MP	SP	ZE
MN	LP	MP	MP	MP	SP	ZE	SN
SN	LP	MP	SP	SP	ZE	SN	MN
ZE	MP	MP	SP	ZE	SN	MN	MN
SP	MP	SP	ZE	SN	SN	MN	LN
MP	SP	ZE	SN	MN	MN	MN	LN
LP	ZE	SN	MN	MN	LN	LN	LN

VI. INTRODUCTION TO FACTS

The process to permit, site, and construct new transmission lines has become extremely difficult, expensive, time-consuming, and controversial. FACTS technologies allow for improved transmission system operation with minimal infrastructure investment, environmental impact, and implementation time compared to the construction of new transmission lines. FACTS controllers control the interrelated parameters that govern the operation of transmission system like series impedance, shunt impedance, current, voltage and phase angle. So FACTS controllers can be utilized to control power flow and enhance system stability [8]. A better utilization of the existing transmission systems by increasing their capacities close to the thermal ratings and enhancing controllability by installing FACTS controllers becomes imperative in today's competitive power market. There are two main aspects that should be considered in using FACTS controllers: The first aspect is the flexible power system operation according to the power flow control capability of FACTS controllers. The other aspect is the improvement of stability of power systems.

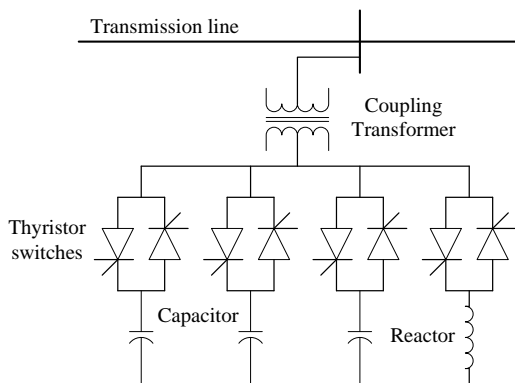

Figure 6.1 : Basic SVC Employing Thyristor Switched Capacitors (TSC) and Thyristor Controlled Reactor (TCR)

The shunt-type FACTS controllers are always used to compensate the reactive power and stabilize the bus

voltage, and the relatively mature shunt-type FACTS devices are SVC (Static Var Compensator) and STATCOM (Static Synchronous Compensator)

A. Static VAR Compensator (SVC)

According to the IEEE terms and definition: "A Shunt-connected static var generator or absorber whose output is adjusted to exchange capacitive or inductive current so as to maintain or control specific parameters of electrical power system (typically bus voltage)". We consider an SVS composed of a controllable reactor and a fixed capacitor. The resulting characteristics are sufficiently general and are applicable to a wide range of practical SVS configurations.

B. Static Compensator (STATCOM)

The STATCOM is made up of a coupling transformer, a VSC, and a dc energy storage device. The energy storage device is a relatively small dc capacitor, and hence the STATCOM is capable of only reactive power exchange with the transmission system [10]. If a dc storage battery or other dc voltage source were used to replace the dc capacitor, the controller can exchange real and reactive power with the transmission system, extending its region of operation from two to four quadrants.

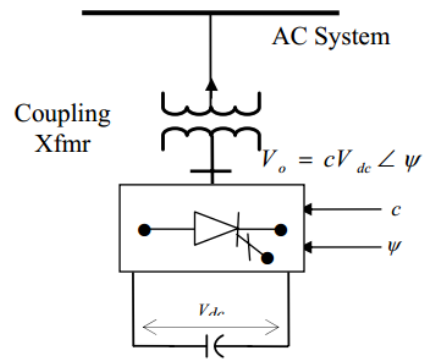

Fig 6.2: STATCOM Configuration

The STATCOM's output voltage magnitude and phase angle can be varied. By changing the phase angle ψ of the operation of the converter switches relative to the phase of the ac system bus voltage, the voltage across the dc capacitor can be controlled [11], thus controlling the magnitude of the fundamental component of the converter ac output voltage, as $V_o = c V_{dc}$.

VII. FACTS WADC

The purpose of FACTS wide area damping control is to shift all the system eigenvalues into the left hand side of the S-plane, so that the needed minimum damping ratio can be satisfied and the system damping can be increased into the acceptable level. As the power oscillation is a prolonged dynamic event, it is essential to vary the applied shunt compensation, and thereby the (midpoint) voltage of the transmission line, to antagonize the accelerating and decelerating swings of the disturbed machine(s). That is, when the rotationally oscillating generator accelerates and angle δ increases ($d\delta/dt > 0$), the electric power transmitted must be increased to compensate for the excess mechanical input power.

Conversely, when the generator decelerates and angle δ decreases ($d\delta/dt < 0$), the electric power must be decreased to balance the insufficient mechanical input power [9]. (The mechanical input power is assumed to be essentially constant in the time frame of an oscillation cycle.). The requirements of Var output control, and the process of power oscillation damping, is illustrated by the waveforms in Figure 7.1. Waveforms in Figure 7.1 (a) shows the undamped and damped oscillations of angle δ around the steady-state value δ_0 . Waveforms in Figure 7.1 (b) shows the undamped and damped oscillations of the Electric power P around the steady-state value P_0 . (The momentary drop in power shown at the beginning of the waveform represents an assumed disturbance that initiated the oscillation). Waveform 7.1 (c) shows the reactive power output on of the shunt-connected Var compensator. The capacitive (positive) output of the compensator increases the mid-point voltage and hence the transmitted power when $d\delta/dt > 0$, and it decreases those when $d\delta/dt < 0$

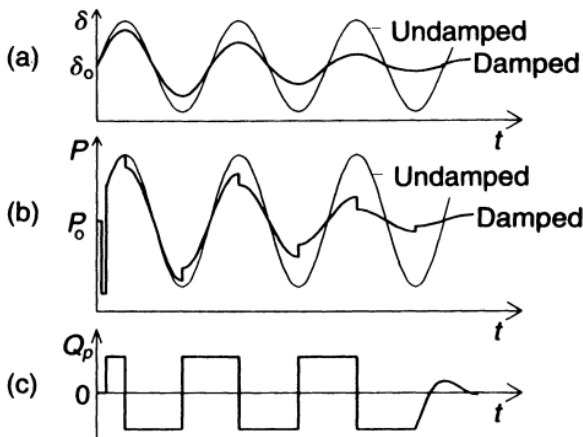

Fig. 7.1: Waveforms illustrating power oscillation damping by reactive shunt compensation: a) generator angle, (b) transmitted power, and (c) Var output of the shunt compensator.

VIII, Closed Loop Verification And Non-Linear Time Domain Simulation

The performance of the proposed power system stabilizer is first verified by small signal analysis. A small disturbance ($1+0.05$) to the voltage reference input of exciter of generator 1 is applied. Time response analysis of the proposed close loop control system is performed for the verification of the expected outcomes. The loads in the system are assumed to be constant impedance type. To damp out local modes of oscillations and inter-area modes of oscillations the tie line is left connected with shunt type FACTS based Wide Area Damping Controller. In order to validate the result, the of signal selection is performed on both the case of STATCOM and SVC which serves as wide area damping controller to the Kundur's two area four machine system used for the case study example. A design of lead-lag compensator based POD (Power Oscillation Damper) is discussed and results of various stability assessment of the designed controller are given in this section. The responses of the tie-line active power flow deviation, change in rotor angle of generator 1 with respect to the variation of the rotor angle of generator 4 and rotor speed deviation of

Generator1 with Conventional Power System stabilizer, fuzzy logic based PSS and coordinated fuzzy logic based PSS with STATCOM Power Oscillation Damping (POD) controller are shown in figure 8.1, 8.2 and 8.3 respectively.

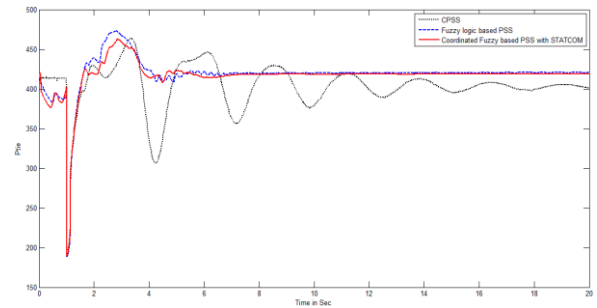

Fig 8.1: Response of tie-line active power flow deviation with STATCOM

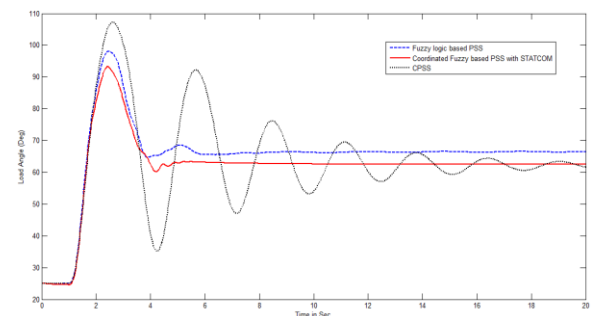

Fig. 8.2: The response of change in rotor angle of generator 1 w.r.t. generator 4

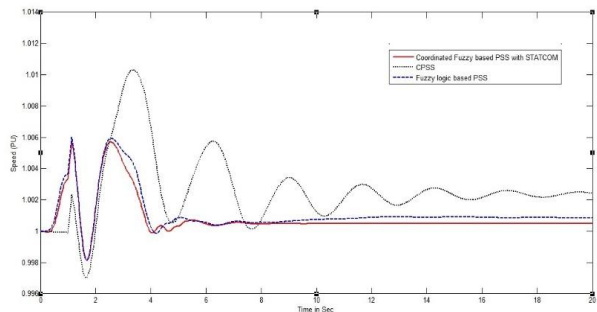

Fig 8.3: The response of rotor speed deviation of Generator1

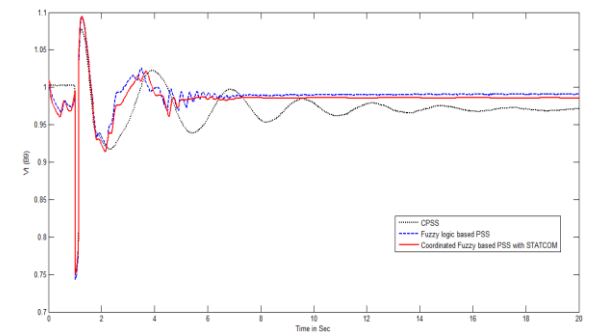

Fig. 8.4: The response of terminal voltage of bus no. 9.

The response of terminal voltage of bus no. 9 where the coordinated fuzzy with STATCOM Power Oscillation Damping (POD) controller has been used as the wide area damping controller is shown in fig. 8.4. The responses of the tie-line active power flow deviation, of rotor speed deviation of Generator1 and change in rotor angle of

generator 1 with respect to the variation of the rotor angle of generator 4 with Conventional Power System stabilizer, fuzzy logic based PSS and coordinated fuzzy logic based PSS with SVC are shown in fig.8.5, 8.6 and 8.7 respectively. The performance responses of coordinated fuzzy logic based PSS with SVC and STATCOM based wide area damping controllers has been studied and it can be concluded from the responses that the STATCOM based WADC provides a better stability response as compared to SVC based controller.

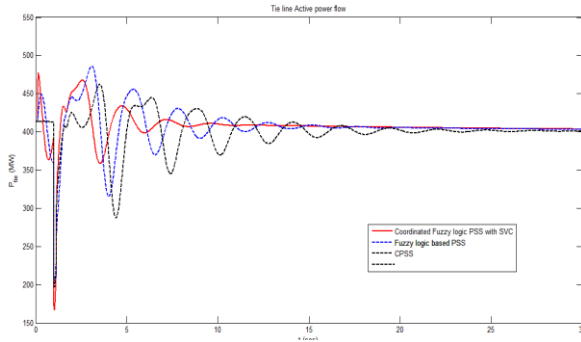

Fig.8.5: The responses of the tie-line active power flow deviation with SVC

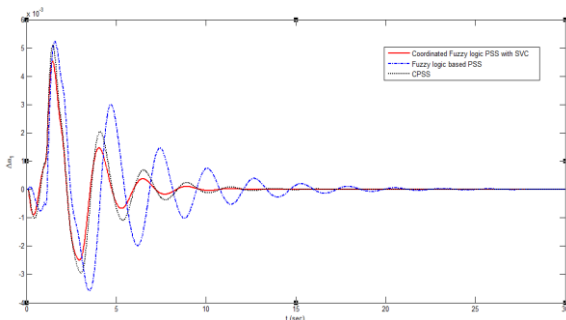

Fig. 8.6: The response of rotor speed deviation of Generator1 with SVC

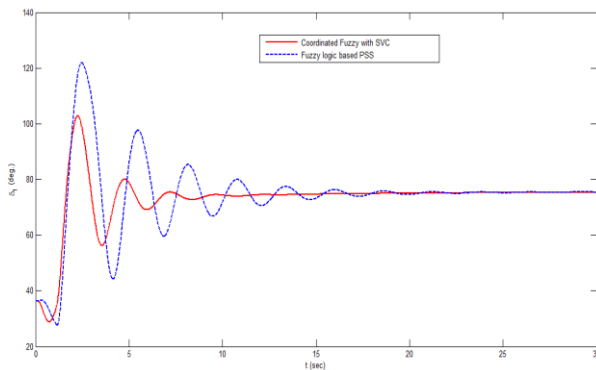

Fig. 8.7 : The response of change in rotor angle of generator 1 with respect to the variation of the rotor angle of generator 4 with SVC

IX. CONCLUSION

In this paper, the present work contributes in the area of power system stability and its improvement using coordinated design of fuzzy logic based damping controllers along with shunt connected FACTS devices. Design the FACTS based controllers and simultaneous tuning of FACTS based controller and fuzzy logic based global PSS has been undertaken. A lead-lag based POD has been designed in the case of power system using STATCOM based Wide Area Damping Controller. In order

to test the performance of the designed STATCOM & SVC based wide-area controller a small signal stability assessment has been performed and the results have been validated.

REFERENCES

- [1]. P. Kundur, 'Power System Stability and Control', TATA McGRW-HILL Edition, 1994.
- [2]. B.C. Pal, 'Robust Control in Power Systems', Springer, 2005.
- [3]. I. Kamwa; M. Dobrescu; A. Heniche; C. Cyr; and Ph. Cadieux; -'A fundamental Study of Wide-Area Damping controllers with Application to Fuzzy-Logic Based PSS Design for Dynamic shunt Compensators' - 17th Power Systems Computation Conference, Sweden, August 22-26 2011.
- [4]. A.M. Almutairi, 'Optimal Input and Output Signal Selection for Wide-area Controllers', IEEE Bucharest Power Tech Conference, Bucharest, Romania, pp. 1-6, 2009.
- [5]. K. Anaparthi, B. Chaudhuri, N. Thornhill, and B. Pal, "Coherency identification in power systems through principal component analysis," IEEE Trans. Power Syst., vol. 20, no. 3, pp. 1658-1660, Aug. 2005.
- [6]. M. R. Shakarami; M. KhoramKhoy, "Selection of an optimal control channel for STATCOM-based stabilizers to damp inter-area oscillations", 22nd IEEE Iranian Conference on Electrical Engineering (ICEE), pp: 580 - 584, 2014
- [7]. Simon P. Teeuwsen, "STATCOM with optimized POD controller for efficient inter-area oscillation damping", IOEEE Power & Energy Society General Meeting, pp: 1 - 5, 2013
- [8]. M. M. Farsangi; Yong Hua Song; K. Y. Lee, "On selection of supplementary input signals for STATCOM to damp inter-area oscillations in power systems", IEEE Power Engineering Society General Meeting, pp: 3068 - 3073 Vol. 3, 2005
- [9]. Aman Ganesh; RatnaDahiya; G. K. Singh, "Wide area adaptive neuro fuzzy STATCOM controller for dynamic stability enhancement", IEEE National Power Systems Conference (NPSC), pp: 1-6, 2016
- [10]. R. Visakhan; R. Rahul; K. R. Hridya; Asha Anu Kurian, "Analysis of power oscillation damping capability of STATCOM-POD and optimal placement of PMUs in IEEE-14 bus system", IEEE International Conference on Power, Instrumentation, Control and Computing (PICC), pp:1-7, 2015
- [11]. R. Visakhan; R. Rahul; Asha Anu Kurian, "Comparative study of PSS and FACTS-POD for power system performance enhancement" IEEE International Conference on Power, Instrumentation, Control and Computing (PICC), pp:1-6, 2015
- [12]. Simon P. Teeuwsen, "POD utilization methods for STATCOMs", IEEE PES General Meeting Conference & Exposition, pp:1-5, 2014
- [13]. N. P. Patidar, M. L. Kolhe, N. P. Tripathy, B. Sahu, A. Sharma, L. K. Nagar and A. N. Azmi, "Optimized Design of Wide-Area PSS for Damping of Inter-Area Oscillations", 2015 IEEE 11th International Conference on Power Electronics and Drive Systems (IEEE PEDS 2015), pp 1-5, 2015.

- [14].A. Sharma, L K Nagar, B Sahu, N. P.Tripathy,N. P. Patidar, "Time Latency Compensation for Wide Area Damping Controller", 6th IEEE Power India International Conference, DTU, Delhi, December 2014.
- [15].N. P. Patidar, J. Earnest, L.K. Nagar, A. Sharma, "Design of Fuzzy Logic based Global Power System Stabilizer for Dynamic Stability Enhancement in Multi-machine Power System", World Academy of Science, Engineering and Technology, International Science Index, Electrical and Computer Engineering, vol. 2(8), pp. no. 323, 2014.
- [16].P. Kundur, J.Paserba, "Definition and Classification of Power System Stability," IEEE Transactions on Power Systems, vol. 19, no.2, pp. 1387-1401, May 2004.
- [17].Gonzalez Miguel Ramirez; Malik O. P.; - 'Simplified Fuzzy Logic Controller and its Application as a Power System Stabilizer', Pub: IEEE, 2009.
- [18].Hariri A.; Malik O.P; - 'A Fuzzy Logic Based Power System Stabilizer with Learning Ability', IEEE Transactions on Energy Conversion, Pub: IEEE, Vol. 11, No. 4, December 1996, pp. 721-727.
- [19].Hoang P.; Tomsovic K;- 'Design and analysis of an adaptive fuzzy Power System Stabilizer', - IEEE Transactions on Energy Conversion, Pub: IEEE, Vol. 11. No. 2, June 1996, pp. 455-461.
- [20].Gharaveisi A. A.; Rafiei S. M. R.; Barakati S.M.; - 'An Optimal Takagi-Sugeno Fuzzy PSS For Multi- Machine Power System', Pub: IEEE, 2008.
- [21].Gowrishankar, K.; Masud Khan, M.D.; - 'MATLAB Simulink Model of Fuzzy Logic Controller with PSS and its Performance Analysis' - IEEE International Conference On Advances In Engineering, Science And Management (ICAESM), Pub: IEEE, March 30, 31, 2012, pp. 541-550.
- [22].Moodley G.V.; Jennings, G.D.; Harley R.G.; Wishart M.T.; - 'Fuzzy Logic Power System Stabilizer in Multi-machine stability Studies', Pub: IEEE, 1996, pp. 843-848.
- [23].Nallathambi, N. ;Neelakantan P. N.; - 'Fuzzy Logic Based Power System Stabilizer' - Pub: IEEE, 2004, pp. 68-73.
- [24].Padhy B. P.; Srivastava S. C; Verma N. K; 'Robust Wide-Area TS Fuzzy Output Feedback Controller for Enhancement of Stability in Multi-machine Power System', - IEEE System Journal, vol. 6, no.3, Sept. 2012, pp. 426-435.
- [25].H. M. Soliman, H.A. Yousef, "Saturated robust power system stabilizers", International Journal of Electrical Power & Energy Systems, vol. 73, pp. 608-614, 2015.
- [26].Y. Zhang, A. Bose, "Design of Wide-Area Damping Controllers for Inter Area Oscillations," IEEE Transac. Power Syst., vol. 23, no.3, pp.1136-1143, Aug. 2008.
- [27].P. Kundur, J.Paserba, "Definition and Classification of Power System Stability," IEEE Transactions on Power Systems, vol. 19, no.2., pp. 1387-1401, May 2004.
- [28].J. Chow J, PST, Power System Toolbox. 2010.